

SYSTEMATIC QUALITY

# LaneLED INOX48

HANDRAIL LIGHTING SYSTEM



Product information



**GIFAS**  
ELECTRIC

09 | 19

## LaneLED INOX48 – the system for self rescue measures in the tunnel and galleries

Various damaging events and fires in train tunnels have shown that it is essential to improve self rescue measures for independent passenger and personnel.

Protection of life and limb – evacuating people – introduce fire-fighting and safety measures.



A system was developed and tested in cooperation with notable manufacturers, which is in line with the requirements of the TSI (technical specification for interoperability - Directive 2008/57/EC of 17/06/2008).

The LaneLED INOX48 Handrail System allows operators and planners to install a complete product, tested as a system, made from stainless steel V4A that meets all technical requirements of the TSI.

The LaneLED INOX48 system from GIFAS is in the implementation phase to be certified according to DIN 4102 Part 12. The certificates are expected in the autumn of 2017:

### LED illuminated handrail with functional maintenance!

Applications:

- railway tunnels
- tunnel lighting
- power plant and cavern corridors
- safety tunnels, access and evacuation tunnels
- mines
- versions with or without functional maintenance

Your advantages:

- easy and quick installation
- type-tested components

TSI - Locomotives  
Spezialgesellschaft für technisches Management

### RAMS-Nachweis

#### Beleuchteter Handlauf LaneLED INOX48 Handrail Lighting System der Fa. GIFAS ELECTRIC Gesellschaft m.b.H

Erstellt durch:  
TSM - Spezialgesellschaft für technisches Management  
Neustadtstrasse 7  
CH-9400 Luzern

Erstellt für:  
GIFAS-ELECTRIC GmbH  
Dietrichstrasse 2  
CH-9424 Rheineck

Erstellt: Dipl.-Ing. Nico Döing  
Dipl.-Ing. Harald Rüdiger  
M.Eng. Alexander Grais

15.02.2021 Version 1.0

Regioverkehr SBB 1-20036 SBB CFF FFS

Regioverkehrsnummer: 24	Intermodalverkehrsnummer: 1000
Umfang: 04.11.2020	Ersteller: SBB CFF FFS
Seitliche Division: Intermodal, Passagierverkehr, Cargo	Benutzer: SBB CFF FFS
Seitliche Einheiten: SBB, SBB, SBB, SBB	Interdisziplinäre Systeme: C, K, L, H
Standort: Regioverkehr 24	Interdisziplinäre Systeme: C, K, L, H
Anforderung: siehe Ziffer 1.3	

#### Selbstrettungsmaßnahmen in Tunnel

Inhaltsverzeichnis

1 Allgemeines	4
1.1 Ausgangslage, Ziele	4
1.2 Geltungsbereich (Unternehmen, Anwender / Funktion)	4
1.3 Übergreifende und zugehörige Dokumente	4
1.4 Begriffe und Definitionen	6
2 Bauliche Elemente für die Selbstrettung	8
2.1 Allgemeines	8
2.1.1 Neubauelemente	8
2.1.2 Bestehende Tunnel	8
2.2 Fluchtwege	9
2.2.1 Allgemeines	9
2.2.2 Neubauelemente	9
2.2.3 Bestehende Tunnel	9
2.2.4 Fluchtwege innerhalb des Tunnels (Sahntunnel)	9
2.2.5 Objektsysteme	9
2.3 Nebenanlagen	10
2.3.1 Neubauelemente	10
2.3.2 Bestehende Tunnel	10
2.3.3 Fluchtwege	10
2.3.4 Fluchtwege	13
2.4 Fluchtwegeführung / Beschilderung	14
2.4.1 Fluchtwegeführung / Beschilderung	14
2.4.2 Beschilderung der Notausgänge	15
2.4.3 Signalisation in Querriegelstellungen	17
2.4.4 Signalisation längs Tunnel	19
2.5 Handlauf	19
2.5.1 Allgemeines	19
2.5.2 Anforderungen Handlauf mit Kabelsystem	19

DMS-ID: 6802887 | Regelverkehrsnummer 3-0 | Seite 1/31 | © 088

AEOLIOS

#### Test report

Dynamic pressure test on two luminaires  
from GIFAS-ELECTRIC GmbH  
Dietrichstrasse 2 - 9424 Rheineck - Schweiz

Adelheim 06.06.2019  
ARHONS  
Stefano Luzzi  
Lindenberg 16  
D-31179 Adelheide

1

7.3.2004 TSI Anhang der Europäischen Union 1 401

ENTSCHEIDUNGEN UND BESCHLÜSSE  
KOMMISSION

ENTSCHEIDUNG DER KOMMISSION  
vom 26. Dezember 2007  
über die technische Spezifikation für die Interoperabilität bezüglich „Sicherheit in Eisenbahntunneln“ im Interoperabilitätssystem für Hochgeschwindigkeitszüge und im Interoperabilitätssystem für Hochgeschwindigkeitszüge

(Bekannt gegeben nach Absatz 14 des Artikels 17 des Vertrags)

(Mit dem Beschluss Nr. 2007/1403/EG)

Die Kommission hat die Interoperabilität von Eisenbahnen im Bereich der Sicherheit in Eisenbahntunneln auf der Grundlage der Europäischen Union...

Typenzulassung

Das Bundesamt für Verkehr hat in der Angelegenheit

Typenzulassungsgesuch der Firma  
GIFAS-ELECTRIC GmbH  
Dietrichstrasse 2, 9424 Rheineck  
Schweiz  
vom 15. Mai 2020

betroffend

Hand-Rail-System LaneLED INOX 48 mit integrierter LED-Beleuchtung für Selbstrettungsmaßnahmen in Eisenbahntunneln

1. Mit Schreiben vom 15. Mai 2020 [1] hat die Firma GIFAS-ELECTRIC GmbH, Schweiz, beim Bundesamt für Verkehr (BfV) ein Gesuch für eine Typenzulassung nach Art. 7 ZBVG für ein Hand-Rail-System mit integrierter Beleuchtung eingereicht.

2. Mit einem vom 10. September 2020 und 11. Dezember 2020 herrührenden Bescheid hat das BfV dem Gesuch mit dem Hinweis auf die Unvollständigkeit der eingereichten Unterlagen keine Folge gegeben.

3. Laut Formularbeurteilung der Bundesbahnen Schweiz sind sich zwei Selbstrettungsmaßnahmen mit integrierter LED-Beleuchtung für Selbstrettungsmaßnahmen in Tunneln und Stationen.

4. Gemäss den Angaben der GIFAS-ELECTRIC GmbH handelt es sich um eine Typenzulassung des BfV im vergleichbaren Produkt mit einem Handlauf aus glanzpoliertem Kupferblech.

5. In Erwägung gesetzt:

Bundesamt für Verkehr BfV  
Mattenstrasse 6  
3003 Bern  
Telefon +41 31 313 1111  
Fax +41 31 313 1112  
www.bsv.admin.ch

Ingenieurbüro Lippold  
Dipl.-Ing. Markus Lippold VDI

Windkanaltechnik  
Beratung  
Planung  
Konstruktion  
Fortzug

#### Pressure strength test on two handrail lights of the company

GIFAS-ELECTRIC GmbH  
Dietrichstrasse 2  
CH-9424 Rheineck

GIFAS-ELECTRIC GmbH  
Pebering-Strasse 2  
A-5301 Eugendorf

Last update: 12.07.2019

Personen:  
Dr. phil. phil. phil.  
Dr. phil. phil.  
Dr. phil. phil.

Adressen:  
10000 Wien  
10000 Wien  
10000 Wien

# System components LaneLED INOX48

## Lighting components

- LaneLED light bar incl. electrical supply

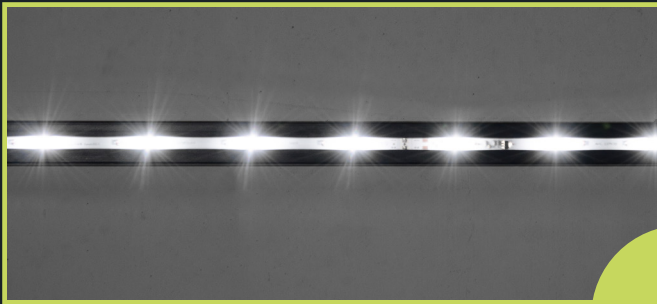

## Mechanical components

- INOX48 – V4A handrail
- wall mounting, brackets and accessories V4A
- connectors and angle parts

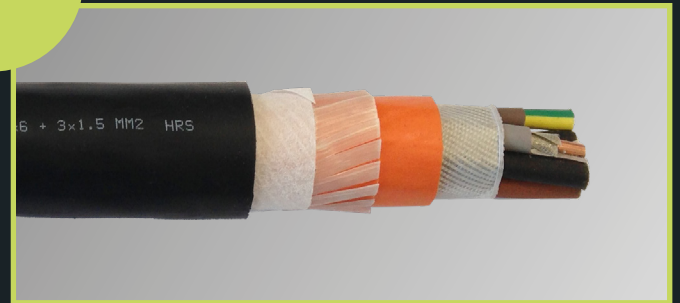
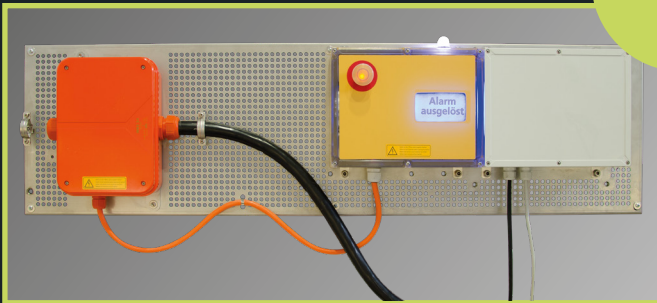

## Safety components

- fire-resistant junction box, fully equipped
- optional alarm unit, individually manufactured
- fire-resistant junction box, fully equipped

## Connecting components

- main or supply cable; project-based for control and supply
- junction, ending and mounting parts

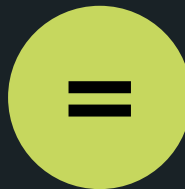

A product that has come from successful GIFAS development!

## LaneLED INOX48

Handrail with integrated emergency escape route lighting

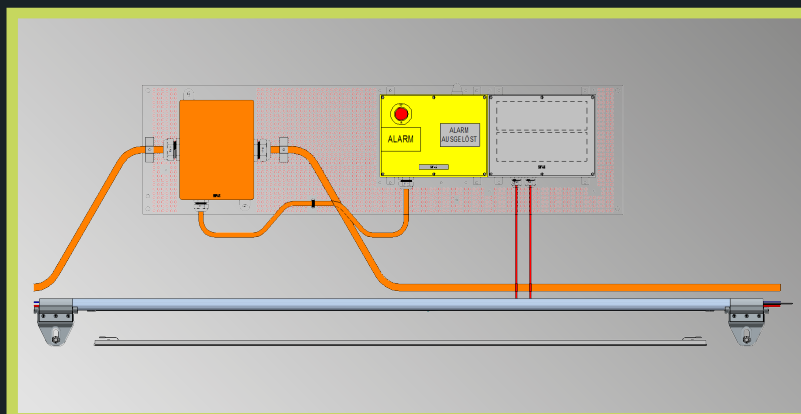

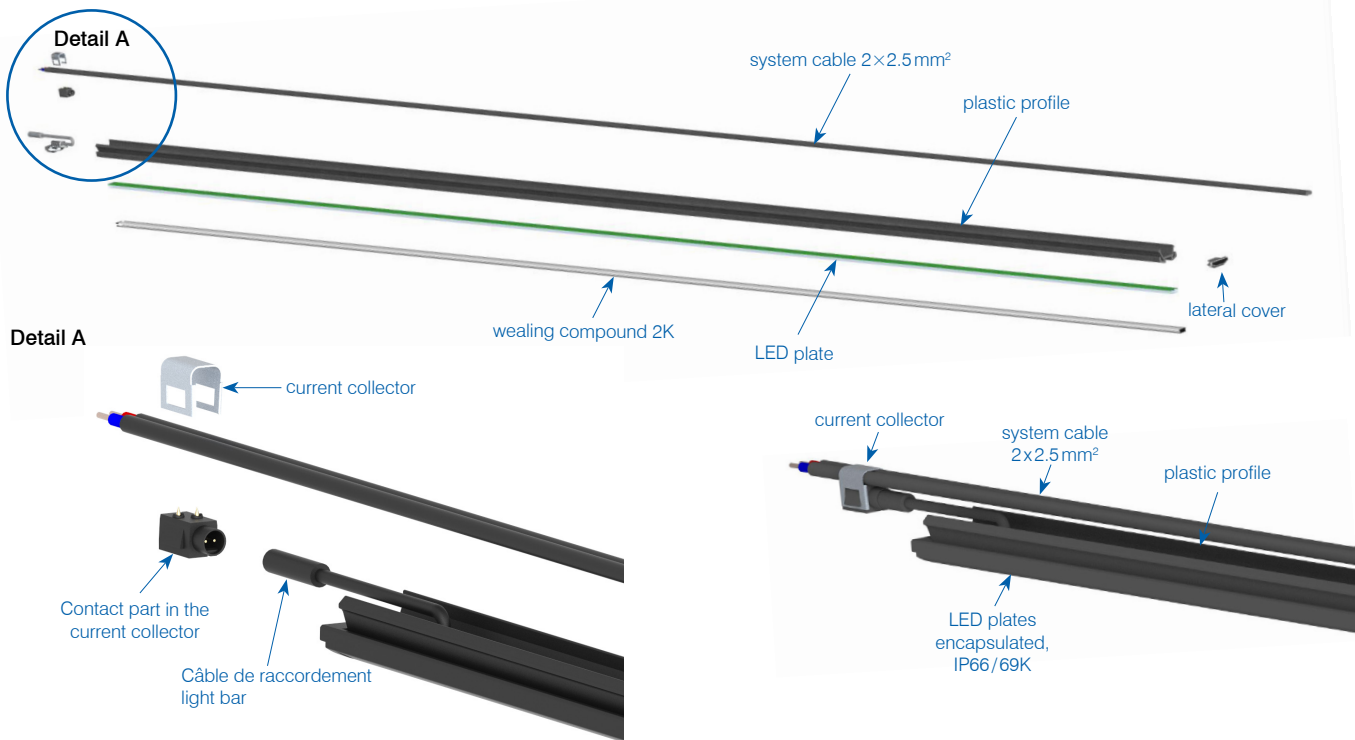

## GIFAS-LaneLED

The «LaneLED» light bar from GIFAS is the base element for the illuminated handrail LaneLED INOX48. The appropriate type is selected depending on the requirements of the operator, whereas the desired average luminance is the most important specification. The other parameters of the LaneLED are carefully defined.

- Light colour: 4'400 K
- Beam angle: 120°
- Operating life: L90/B10 100'000 h +25° C
- Protection category: IP66/69K
- Operating range of temperature: -25° C to +45° C

## Composition of the LaneLED

The carrier profile of the «LaneLED» light bar consists of a special synthetic profile with special characteristics for mechanical and chemical strains.

A flexible and separable LED strip is inserted from below and incorporated into the profile with 2K casting compound. The encapsulation leads to the high protection class of IP66/69K.

There is room for the cable guide and the current collector in the upper part of the profile (in between the flanks).

## Light bar LaneLED

GIFAS-LaneLED coated with special profile plastic, approx. 30x26.5x2'227mm with LED modules 21-32VDC, 4'400K, beam angle 120°, completely ready for connection, not including assembly materials (system cable and current collector). Assortiment see page 5.

## Illumination

Light emission when using INOX48.

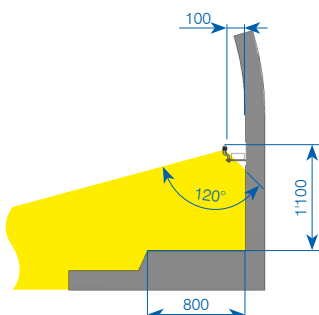

## Current collector type SNAP

Each individual LaneLED is connected to the power supply via the current collector and is freely attachable to the flat cable 2x2.5mm². The cable bushing serves as the interface to the current collector and the connection cable with plug 2P of the LaneLED (IP66/69K connection).

### Type SNAP

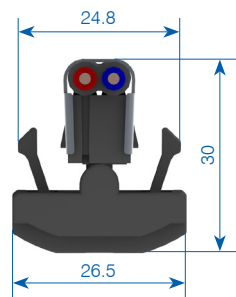

View: cut profile with current collector

### Type SCREW

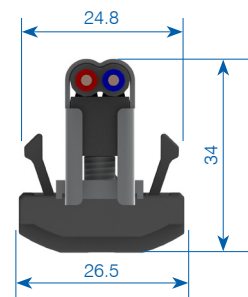

View: cut profile with current collector

## Accessories LaneLED

Item no.	Description
209768	LED, system cable black, 2x2.5mm² flat cable CPR B2ca XLPO/XLPO
209769	LED, system cable blue, 2x2.5mm² flat cable CPR B2ca XLPO/XLPO
209770	LED, system cable red, 2x2.5mm² flat cable CPR B2ca XLPO/XLPO
136230	LED, current collector SCREW 2P, 42V-5A, V4A 1.4401, with metal bracket, thread base plate and set screw
860120	LED, current collector SNAP 2P, 42V-5A, V2A 1.4310 (requires special pliers Item no. 860565)



# Light data / Assortment LaneLED INOX48

## Technical data LaneLED – Light comparison measurements

Perfect light for each application! An overview of the values that can be achieved with light bars LaneLED type 1 to 5 follows.

- maintenance factor: 1 (value as new)
- light mounting height: 95 cm
- emergency escape route width: 1 m

## Redundancy

The LaneLED light bar has two independent lighting circuits, which are fed separately. This ensures that, if one lighting circuit fails (power supply failure, wire breakage, electronics defect, etc.) the LaneLED light bar retains 50% of its functionality.

## Standard assortment

Item no.	Length mm	Number of LED	Output W	Power mA	Luminous flux lm
----------	-----------	---------------	----------	----------	------------------

### Type 1: LaneLED INOX48, 4'400 K, 21 -32 VDC

860353	380	12	0.12	5	8
860354	1118	36	0.36	15	24
860355	2224	72	0.75	30	48

### Type 3: LaneLED INOX48, 4'400 K, 21 -32 VDC

860356	380	12	0.5	20	32
860357	1118	36	1.5	60	96
860352	2224	72	3.0	120	192

### Type 4: LaneLED INOX48, 4'400 K, 21 -32 VDC

860514	380	12	1.0	40	64
860515	1118	36	3.0	120	192
860516	2224	72	6.0	240	384

### Type 5: LaneLED INOX48, 4'400 K, 21 -32 VDC

860358	380	12	1.5	60	96
860359	1118	36	4.5	180	288
860360	2224	72	9.0	360	576

Other versions on request

## Redundant assortment

Item no.	Length mm	Number of LED	Output W	Power mA	Luminous flux lm
----------	-----------	---------------	----------	----------	------------------

### Type 2: LaneLED INOX48 redundant, 4'400 K, 21 -32 VDC

860361	384	12	2×0.12	2× 5	2× 8
860362	1122	36	2×0.36	2×15	2×24
860363	2227	72	2×0.75	2×30	2×48

### Type 3: LaneLED INOX48 redundant, 4'400 K, 21 -32 VDC

860364	384	12	2×0.25	2×10	2×16
860365	1122	36	2×0.75	2×30	2×48
860366	2227	72	2×1.50	2×60	2×96

### Type 4: LaneLED INOX48 redundant, 4'400 K, 21 -32 VDC

860520	384	12	2×0.50	2× 20	2× 32
860521	1122	36	2×1.50	2× 60	2× 96
860522	2227	72	2×3.00	2×120	2×192

### Type 5: LaneLED INOX48 redundant, 4'400 K, 21 -32 VDC

860367	384	12	2×0.75	2× 30	2× 48
860368	1122	36	2×2.20	2× 90	2×144
860369	2227	72	2×4.50	2×180	2×288

Other versions on request

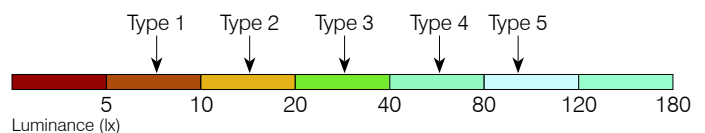
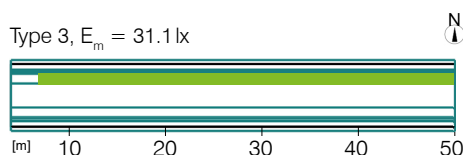
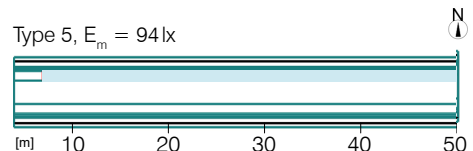
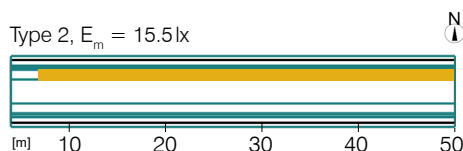
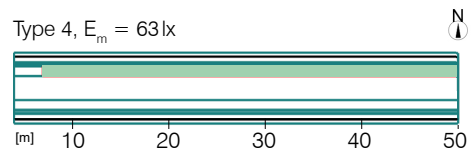
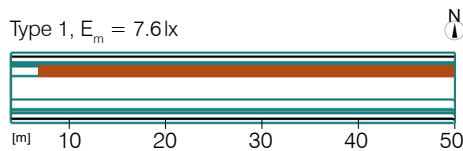

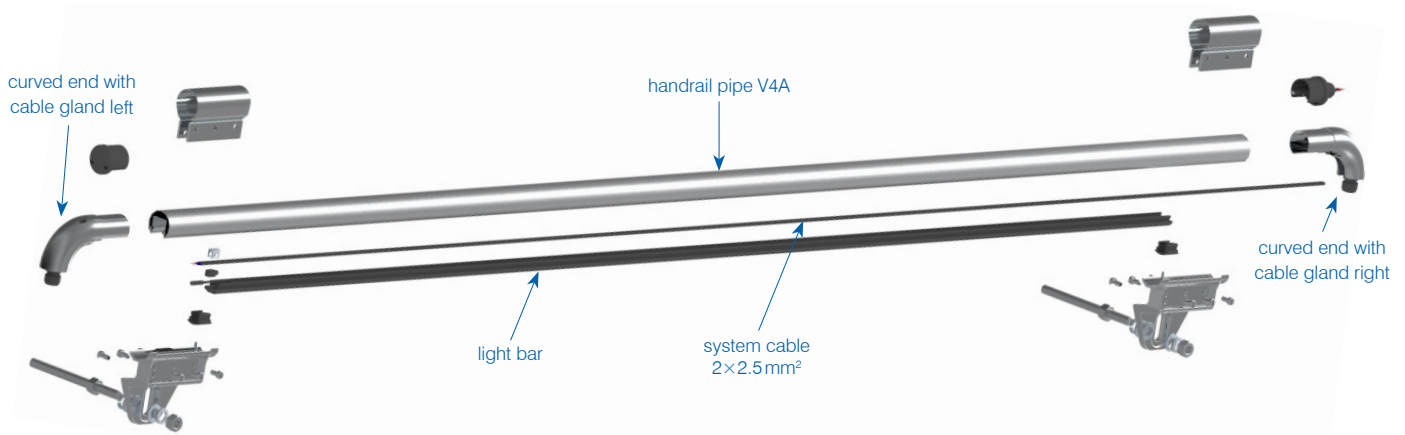

## Handrail – INOX48

The LaneLED INOX48 handrail, made from stainless steel V4A, is the alternative to the LaneLED GFK handrail if the requirement or specification is for stainless steel.

The profile shape is selected to guarantee the safety handrail function, as also to allow the installation of the light bar (by click function) and the necessary power supply. The handrail has been a proven product for many years, with conceptual adaptations for use as self-rescue measures in railway tunnels.

- Handrail pipe V4A, steel 1.4571, (AISI 316Ti), cold-rolled
- special accessories for quick and easy assembly
- many specific featured items for special solutions

## Profile Handrail

The profile for the LaneLED handrail is the core element of the setup. The LaneLED light bar (supplied with the necessary installation items) is clicked into the «light slot» from below after completing the hand rail assembly.

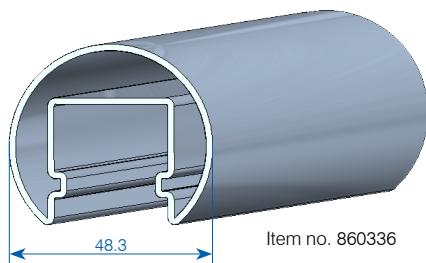

## Blind cover and securing element

Similar in design to the LaneLED profile, a blind cover is available that covers gaps in the longitudinal direction. A securing element is used for the assembly.



## Handrail bracket

The specially designed handrail bracket, made from V4A steel casting, is placed directly on the anchor rod. It is designed in such a way that the mounting tolerances can be absorbed in all three axes. It also guarantees proper and quick assembly.

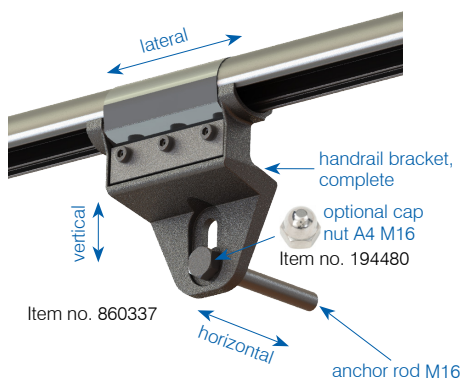

## Insulating piece

An insulating piece is available to avoid potential shift and to separate electrically individual supply sections from each other.



## Corner connector

Angle connectors are used to change the direction. The supply cable can be inserted inside without interruption. The angle connectors allow changes in direction of  $+30^\circ$  and  $-30^\circ$ .



Item no. 860850



Item no. 860851

## Corner connector

A corner connector is used for any direction change (horizontal and vertical). The supply cable can be inserted without any interruption. The corner connector allows a directional change of  $\pm 90^\circ$ .

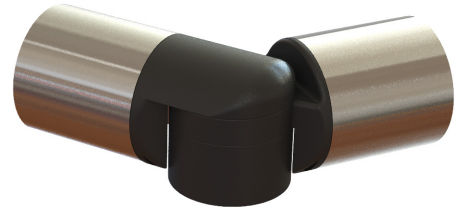

Item no. 860341

## For direct feeding via handrail pipe profile

A supply element, straight and angled connection nipples as well as the appropriate flexible conduit are available for feeding via the handrail pipe profile.



Item no. 155544



Item no. 155547



Item no. 218301

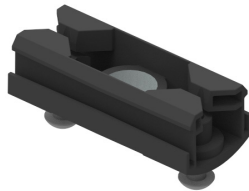

Item no. 860843

## Optional bypasses

Bypasses in all directions can also be realised by means of corner connectors.

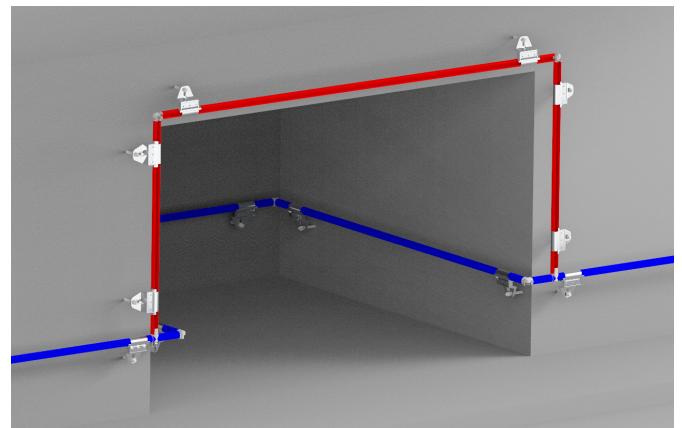

## Handrail elbow left / right supply element

Two curved ends (left / right) with cable inlet for the supply are available.



Item no. 840656



Item no. 840657

## End cap

There are three end caps in the product range (with/without cable gland).



Item no. 860339

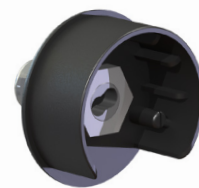

Item no. 860340



Item no. 194479

## Optional cable conduit

The handrail can be used either with or without a cable conduit (cable tray). A cable tray can be secured to the M16 anchor rods by pipe clamps.

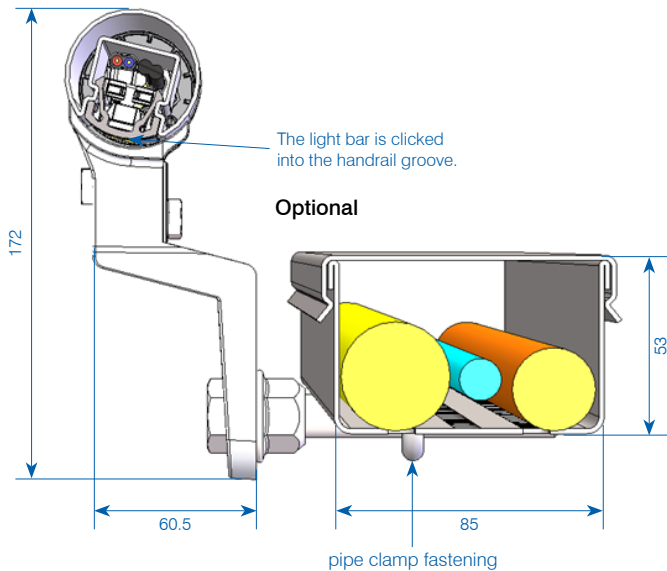

## Optional sign lighting

Certain elements of the hand rail can be turned 180° upwards for any necessary lighting of warning signs (installed above the hand rail). This does not interfere in any way with the overall appearance of the illumination.

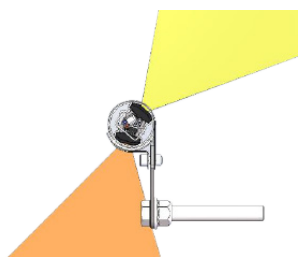
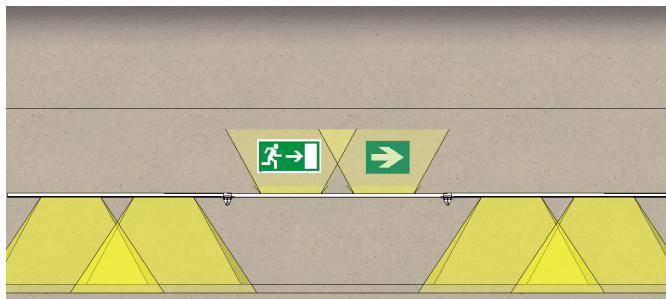
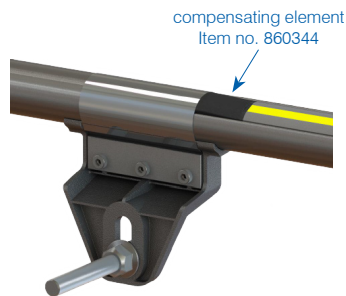

Art.-Nr.	Beschreibung
860336	LaneLED INOX48, LED hand rail tube V4A, steel 1.4571 Ø48.3×1.5 mm, length 2'500 mm, cold-rolled
860337	LaneLED INOX48, hand rail support V4A, 1.4401 incl. clamping plate and securing screws
194480	LaneLED INOX48, cap nut A4, M16 high profile
860842	LaneLED INOX48, hand rail support V4A, 1.4401 with end connection incl. clamping plate and securing screws
860343	LaneLED INOX48, blind cover V0 UL94
860342	LaneLED INOX48, securing element GRP, V0 UL94
860345	LaneLED INOX48, insulating piece GRP 15kV, plastic pipe 1½", length 350 mm
860850	LaneLED INOX48, elbow V4A 30° right closed, light inclination 20°
860851	LaneLED INOX48, elbow V4A 30° left closed, light inclination 20°
860341	LaneLED INOX48, corner connector GRP, V0 UL94
860843	LaneLED INOX48, supply element GFK, V0 UL94 with thread M16
218301	Conduit gland AGRO M16 sz 90°, for plastic hose ø15.8 mm
155544	Conduit gland AGRO M16 sz straight, for plastic hose ø15.8 mm
155547	Flexible conduit ROHRFLEX PA12 black 12, 0/15.8 mm flexible (VE=50 m)
840656	LaneLED INOX48, curved end with cable gland right
840657	LaneLED INOX48, curved end with cable gland left
860339	LaneLED INOX48, end cap GRP, V0 UL94
860340	LaneLED INOX48, end cap GRP with cable gland M20, V0 UL94
194479	LaneLED INOX48, end cap V4A
860344	LaneLED INOX48, compensating element GRP, V0 UL94
170859	LaneLED INOX48, cable channel V4A, steel 1.4571 80×59, 2×1.0 mm, length 2'500 mm, cold-rolled
170860	LaneLED INOX48, cable tray cover V4A, stainless steel 1.4571 80×20×1.0 mm, length 2'500 mm, cold-rolled
170890	LaneLED INOX48, cable tray connector V4A, stainless steel 1.4404, 36×2'135×1.0 mm, (2 pcs. per connection)
181242	LaneLED INOX48, cable tray connector, screw kit M6-8 pcs. (PU 100)
181243	LaneLED INOX48, cable tray mounting kit/pipe clamp M6-2 pcs. (PU 10)



## Feeding unit

The orientation light in the hand rail is supplied by the feeding unit. At the same time, it ensures connection to the mains and also fulfils the relevant regulations for fire-resistant design. In order to make assembly easier, the feeding unit is mostly pre-assembled on a mounting plate at the factory.

A feeding unit consists of a maximum of 3 elements:

- junction box E30/E90
- control-/alarm unit
- mains supply distributor

Example: (In accordance with SBB directive 1-20036)

Feeding unit design, alarm button at the front (Item no. 130352)

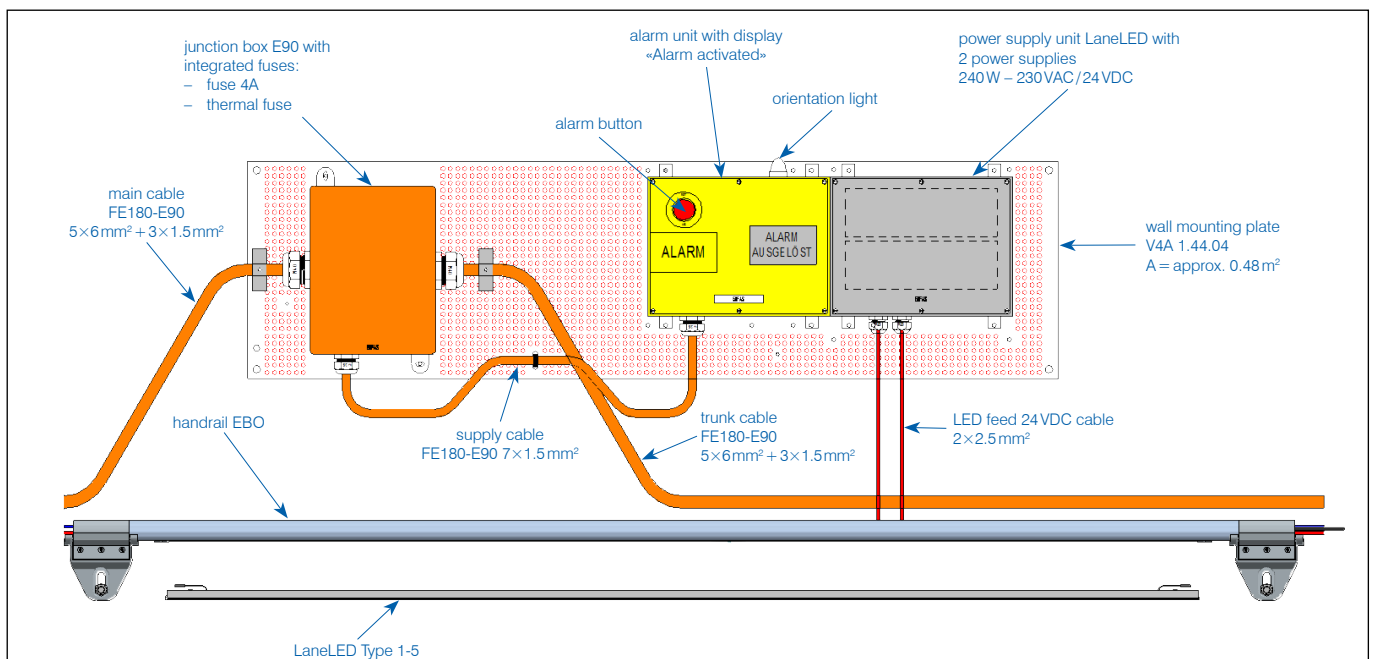

Feed concept of the supply section (length of lines are project specific)

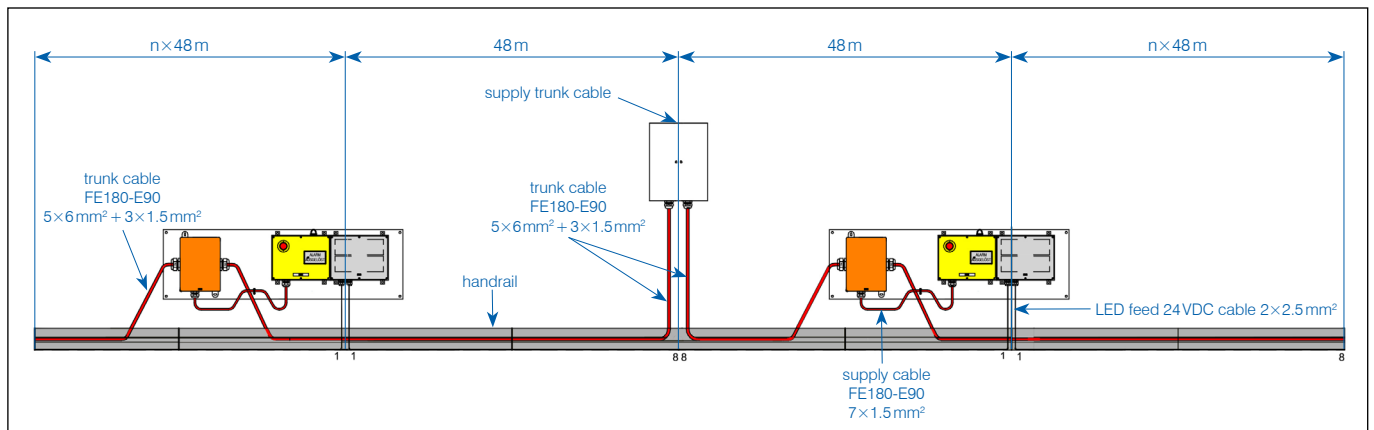

## Feeding unit without BG alarm (Item no. 134388)

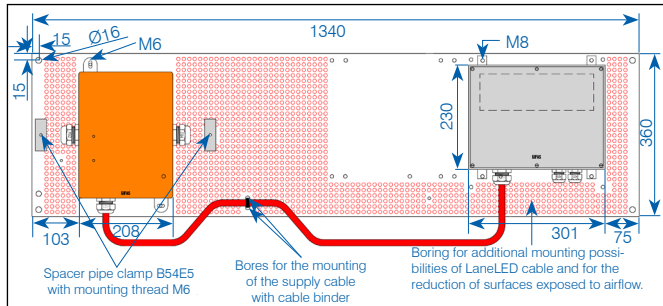

## Example feeding units

Item no.	Description
130352	LaneLED, feeding unit E30/E90 complete to plate V4A BFA, alarm (ME+A at the front), mains unit 2×240 W
134388	LaneLED, feeding unit E30/E90 complete to plate V4A BFA, mains unit 240 W
177406	LaneLED, anchor rod V4A, M12×200mm, including incidentals
177409	LaneLED, injection mortar 500 ml to anchor rods for: 30 pieces. M16/ 40 pieces. M12

Other versions on request

## Examples for power supply cabinet

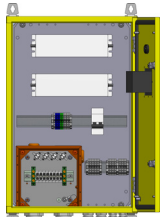

Item no. 188456

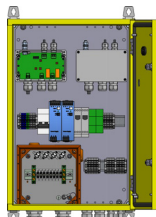

Item no. 192834

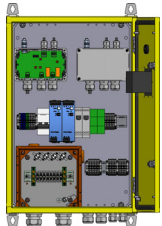

Item no. 193933

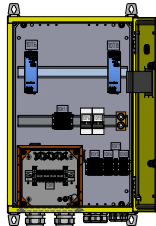

Item no. 213219

Item no.	Description
188456	LaneLED, power supply cabinet, 1.4301 (V2A) RAL 1023 (yellow signal colour), 400×645×260.8 mm 2 power supplies 230VAC/24VDC-20 W, IP66
188456	LaneLED, power supply cabinet, 1.4301 (V2A) RAL 1023 (yellow signal colour), 400×645×260.8 mm 2 power supplies 230VAC/24VDC-240 W, IP66
192834*	LaneLED, power supply cabinet, 1.4301 (V2A) RAL 1023 (yellow signal colour), 400×645×261 mm 2 power supplies 230VAC/24VDC-240 W, IP66
193933**	LaneLED, power supply cabinet, 1.4301 (V2A) RAL 1023 (yellow signal colour), 400×645×261 mm 2 power supplies 230VAC/24VDC-240 W, IP66

Other versions on request

\* plus failure monitoring when switched off (cold conductor monitoring), failure monitoring during operation (current monitoring relay) and power supply feedback via DC-OK contact

\*\* power supply feedback via DC-OK contact

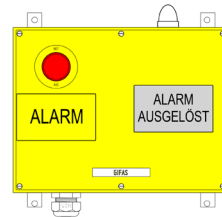

Item no. 136104

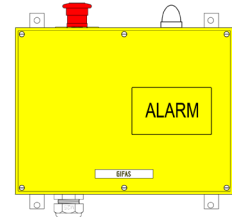

Item no. 136136

## Spare for SRM\* SBB AG

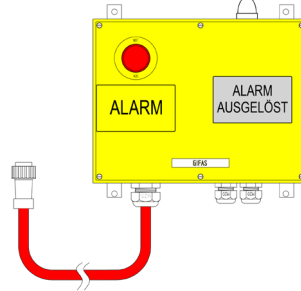

Item no. 155622

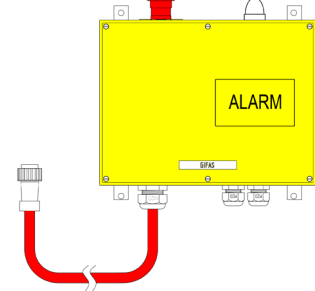

Item no. 155624

\*SRM = self-rescue measure

## Standard item control-/alarm unit

Art.-Nr.	Beschreibung
136104	LaneLED, alarm unit, plastic Schaltbau, 300×230×110mm, with alarm button at the front, with display at the front, IP66
136136	LaneLED, alarm unit, plastic Schaltbau, 300×230×110mm, with alarm button above, without display, IP66
155622	LaneLED, alarm unit, plastic Schaltbau, 300×230×110mm, with alarm button at the front, with display at the front, IP66, with connection cable
155624	LaneLED, alarm unit, plastic Schaltbau, 300×230×110mm, with alarm button above, without display, IP66, with connection cable

Other versions on request

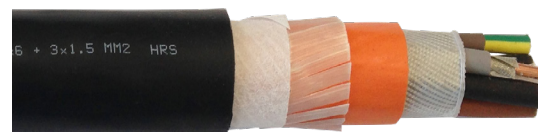

## Cable

The trunk or feeder cables are also dependent on device: With/without callback, fireproof cabling to FE1800/E90 or FE05 finish. We are happy to advise!

Item no.	Description
141138	LaneLED, high voltage cables FE180/E90 Hybrid, balck, 5×6 mm <sup>2</sup> (LNPE) + 3×1.5 mm <sup>2</sup> (1-3), Ø 29.4 mm
178362	LaneLED, supply cable FE180/E90, orange, 5×6 mm <sup>2</sup> (LNPE), Ø 20.1 mm
115421	LaneLED, supply cable FE180/E30, orange, 5×6 mm <sup>2</sup> (LNPE), Ø 14.2 mm
037552	LaneLED, control cables FE180/E30, orange, 3×2.5 mm <sup>2</sup> (LNPE), Ø 9.9 mm
132930	LaneLED, control cables FE180/E30 orange, 7×1.5 mm <sup>2</sup> (Num. + PE), Ø 11.5 mm

Other versions on request

## Our services

- planning and concept development as per specifications
- relux lighting calculation
- assembly support on site
- consultation and support through our field service
- creation of object-specific plans and documents

## Assembly

- ask for our detailed installation instructions!

 A complete system can be viewed in the «Hagerbach» test gallery



## Assembly equipment for rent

Item no.	Description
138174	Assembly training for feeding unit
138524	LaneLED cable reel trolley for cable reel max. Ø500×500
176955	Wall scanner (for object detection inside walls)
137634	LaneLED GFK installation holding tool aluminium, 270×50×40 mm
860565	Crimping tool mechanical for current collector / system cable
179280	Battery pack 24V, 7.2Ah

Other versions on request



Item no. 860565



Item no. 176955



Item no. 179280



Item no. 137634



Item no. 138174

Item no. 138524



GET IN TOUCH WITH US

News about the assortment and specific solutions  
you can find on our website:

[www.gifas.ch](http://www.gifas.ch)

We reserve the right to make technical modifications. V0821



**GIFAS**  
ELECTRIC

GIFAS-ELECTRIC GmbH  
Dietrichstrasse 2  
CH-9424 Rheineck

+41 71 886 44 44  
+41 71 886 44 49  
info@gifas.ch  
[www.gifas.ch](http://www.gifas.ch)